

# X-ray inspection system Dylight

The easy 'Plug and Play' solution



## ⓘ Advantages

- Extremely compact design
  - Plug and Play: All functions in one unit
  - Takes up only one metre of space in your production line
  - Complete with separator and run-off container
- Maximum product safety thanks to the highest degree of detection sensitivity
- Intuitive, time-saving operation
- Easy installation and integration into networks



The X-ray inspection system Dylight guarantees extremely high levels of safety for your packaged food. This true 'Plug and Play' solution combines all functions in one compact unit.

## Product quality and safety for small packaged food

- ⓘ Dylight reliably detects metal, stone, plastic, bone and glass foreign objects and reliably excludes **imperfect or contaminated products**.
- ⓘ Increase operating time with Dylight: The **intuitive user interface** reduces operating errors to a minimum. New products can be configured quickly and conveniently.
- ⓘ All the functions you require — **including a blower for separation and a run-off container** — are combined in one compact unit that takes up a **width of just one metre exactly** in your production line.
- ⓘ The X-ray inspection system Dylight can be integrated into any network via **SPC@Enterprise, OPC-UA, ModBus and Ethernet**.

# Extremely high levels of product safety in even the tightest of spaces

With the X-ray inspection system Dylight, Minebea Intec is offering a 'Plug and Play' product which is ideal for integration into existing production environments thanks to its reduced size. The system is perfectly suited for the inspection of small and light foodstuffs, such as snacks, energy bars, sweets and crisps. The system boasts a high level of efficiency, and saves valuable space on your production line thanks to its compact design.

Available with OPC-UA and connection to SPC@Enterprise

## X-ray inspection system Dylight scale drawing

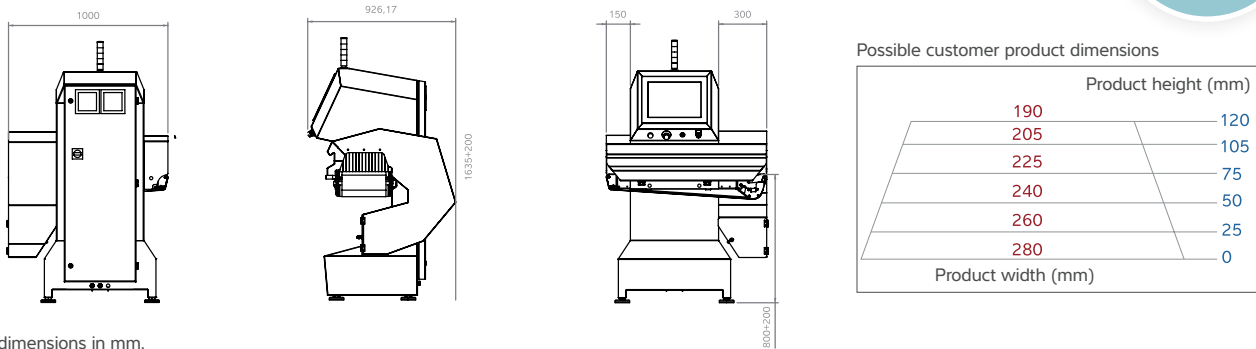

All dimensions in mm.

## Technical data – X-ray inspection system Dylight

X-ray power	65 kV 1 mA
Detector resolution	0.8 mm (standard)   0.4 (optional)
Belt speed range	10 to 49 m/min (with drum motor)
Approvals	CE UL
Safety locks	SIL 3 Category IV PL e, magnetic
User interface	15-inch touchscreen
Operating temperature	+5° to 35°C
Machine cooling	Air cooling IP 54
Relative air humidity	20% to 90%, no condensation
Digital outputs	16 available
Digital inputs	16 available
USB port	Yes
Network connection	Ethernet
Compressed air	5.5 to 6.9 bar
Radiation safety	FDA CFR 21 part 1020.40
International protection class	IP 54 (complete system)   IP 65 (in detection area)
Electrical supply	230 V <sub>AC</sub> ± 10% 50/60 Hz (standard) / 190 to 240 V <sub>AC</sub> 50/60 Hz (optional)
Conveyor height	800 mm (+200 mm)
Conveyor width	275 mm
Conveyor belt	FDA approved
Safety curtains	Lead-free
Languages available	German, English, Italian, French, Polish, Spanish, Hungarian (Chinese and Korean on request)

## Options

Various additional options

- Remote control
- Extended warranties
- Bar code reader
- Acoustic signal emitter
- Service contracts

The technical data given serves as a product description only and should not be understood as guaranteed properties in the legal sense.

Specifications subject to change without notice.

Last updated 05/2017

UK Inspection Systems Ltd  
 Unit 15, Hercules Way  
 Farnborough Aerospace Centre  
 Farnborough, Hampshire GU14 6UU  
 Tel: 01252 510565  
 sales@ukinspectionssystems.com  
 www.ukinspectionssystems.com