



FORTIS PLUS METAL DETECTOR

Designed for Food & Packaging Industries

The Fortis Plus bulk detector is the larger cousin of the Fortis metal detector, which has been designed with the customer in mind by delivering low cost of ownership and simple maintenance. The Fortis Plus is supplied as standard in Alarm and Stop configuration with key switch reset.



Features include:

- Designed and built in the UK
- Delivers high detection performance to withstand the demanding rigours of the industry
- Washdown IP66 rated
- Constructed to minimise bug traps but facilitate easy and effective washdown
- Multilevel password protection
- Full range of aperture sizes to suit products inspected

The system combines a high-performing and reliable search head with an extremely robust conveyor and control system.

The search head can be supplied in a variety of sizes to suit most standard box applications and uses powerful Digital Signal Processing technology and high sensitivity levels to ensure the detection of the smallest ferrous, non-ferrous, and stainless-steel contaminants.

The conveyor system and controls are designed to be extremely user friendly and keep maintenance and repair times to a minimum. A robust direct drive DC motor eliminates the need for pulleys and belts and the heavy-duty frame and bearings mean the machine is built to last.

A unique feature of the Fortis is its ability to be able to adapt to changing customer needs. The machine handling can be changed to accommodate changes in factory layout to reduce the need to purchase new machinery.



FORTIS PLUS METAL DETECTOR

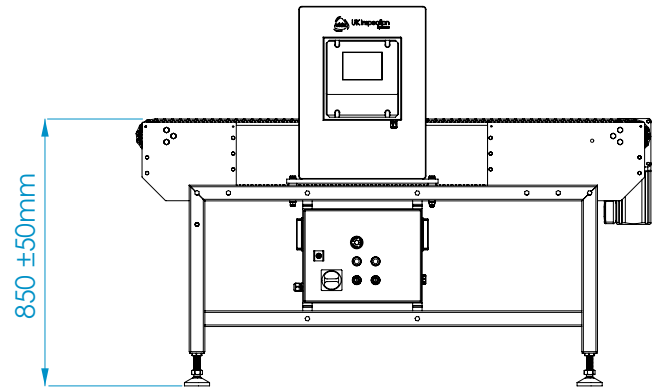
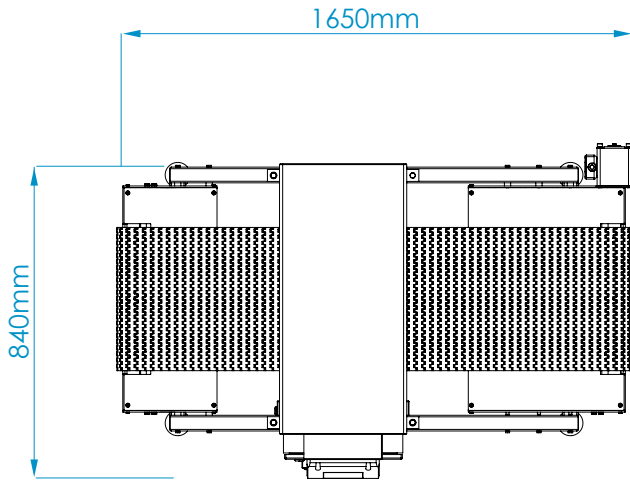

Specification

- Finish:** Polished Stainless Steel
- Height:** 850mm +/- 50mm
- Length:** 1650mm standard (+ 100mm if req'd)
- Width:** 840mm
- Head size:** Various sizes available
- Belt type:** Modular or PU
- Belt width:** 450mm
- Reject:** Alarm and Stop
- Electrical:** 220-240V single phase 16 Amp 50-60Hz
- Warranty:** 1 year

Applications

- Bakery
- Cereal
- Confectionery
- Dairy
- Fish
- Packaged Products
- Fruit & Vegetables
- Meat & Poultry
- Nuts & Grains
- Snack Foods
- Dried Fruits
- Textiles

Options

- Ethernet
- Data Collection
- Spares Kit
- Extended Warranty
- Production Support Package

01252 510565

sales@ukinspectionssystems.com

www.ukinspectionssystems.com

Head Office:

Unit 15, Hercules Way
Farnborough Aerospace Centre
Farnborough
Hampshire, GU14 6UU

Manufacturing:

Units 5 & 6, Elan Court
Norris Way
Rushden
Northants, NN10 6BP



Registered in England: Number 06932748

