

X-ray inspection system Dymond

Safety and product quality for packaged food



ⓘ Benefits

- Extremely high level of detection sensitivity with low energy consumption
- Reliable detection of a wide range of foreign objects for your packaged products
- From large to small: the perfect solution for every product size
- Easy and intuitive operation by teaching in the products



The innovative X-ray inspection system Dymond reliably detects foreign objects, including in desserts, salad mixes or ready-made meals. At the same time, the system helps to check important quality attributes, such as mass, filling levels, completeness and integrity.

For reliable inline inspection of packaged food

- ⓘ For maximum product quality, Dymond reliably detects **foreign objects, such as metal, glass, stone, bone and various plastics** – regardless of their shape, size and position.
- ⓘ Dymond guarantees **safe inspection of food products** in cartons, boxes, sachets, bags, trays and even metallised single portion packs.
- ⓘ The X-ray inspection system comprises four configurable models for **a range tailored to every requirement**. Belt widths of up to 800 mm allow multi-lane applications with a maximum of eight lanes.
- ⓘ The X-ray inspection system Dymond can be integrated into any network via **SPC@Enterprise, OPC-UA, ModBus and Ethernet**.

Dymond – Inline inspection and integration into your networks

All of the Dymond series X-ray inspection devices guarantee reliable vertical inspection. Foreign objects made from metal, glass, stone, bone and various plastics are detected inside food packaging and eliminated from the production line. A broad range of standard functions also ensure product integrity and quality, for example through



completeness checks

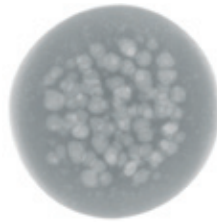

product weighing

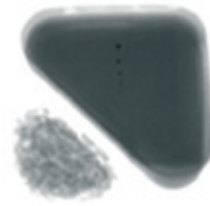

determining weight of individual areas

Integration

Easy integration into your production

The Dymond series systems can be quickly and easily integrated into your production for systematic checking and analysis of machine and line performance. We offer interfaces to

- **SPC@Enterprise**
- **OPC-UA**
- **Modbus**
- **Ethernet**



SPC@Enterprise from Minebea Intec converts measured data into useful information, which helps to ensure product quality, food safety and productivity.

Dymond 40, 80, 120, 160 scale drawings

The Dymond series sets a new standard in X-ray inspection for food with crystal-clear X-ray images, a high degree of accuracy and low energy costs – all available in four different machine sizes. Simply choose the right solution for your products.



Dymond 40

Front view

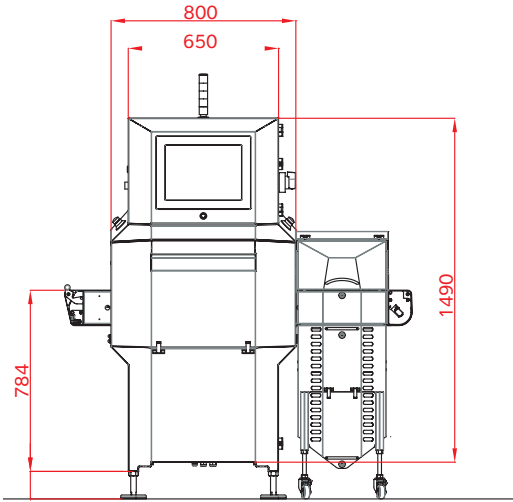

X-ray beam geometry

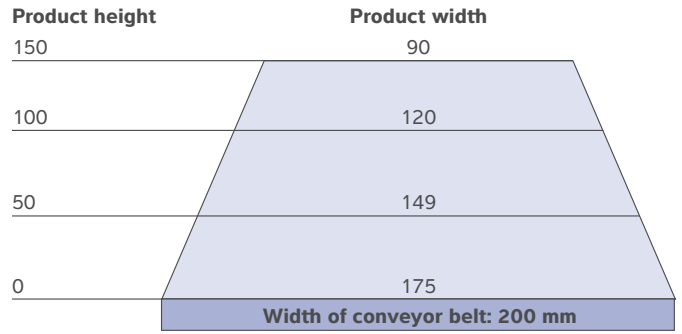

Side view

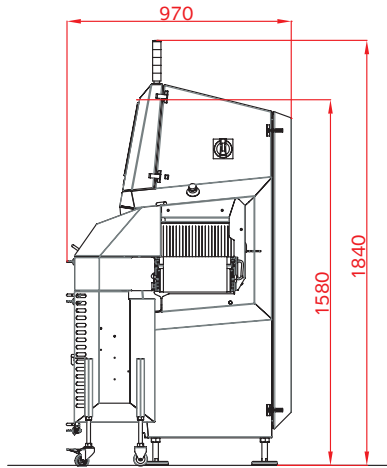

Rear view

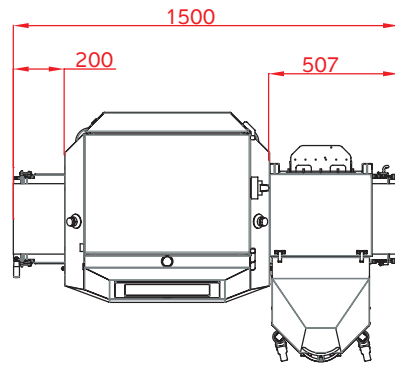

Dymond 80

Front view

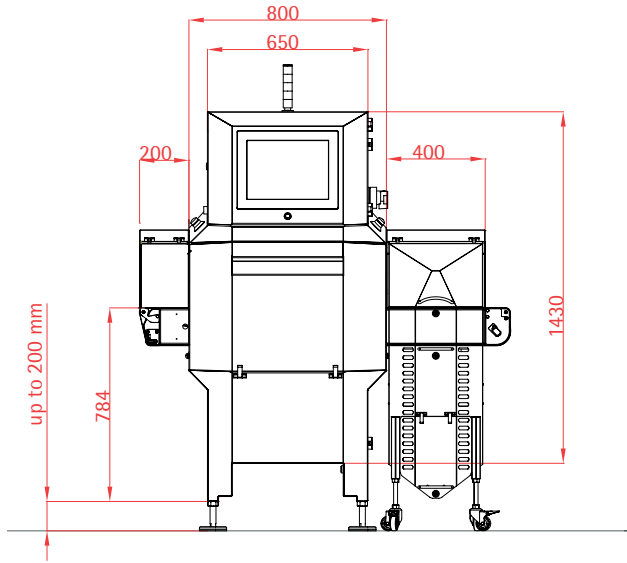

X-ray beam geometry

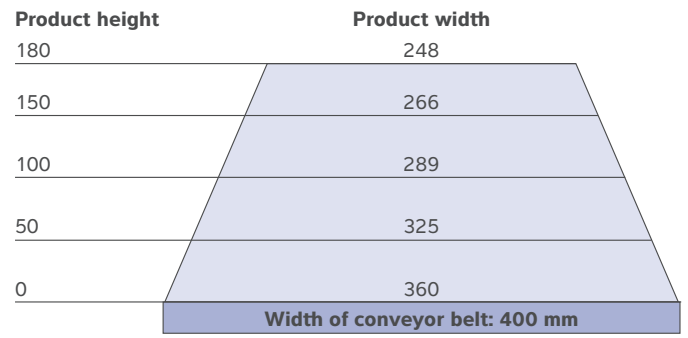

Side view

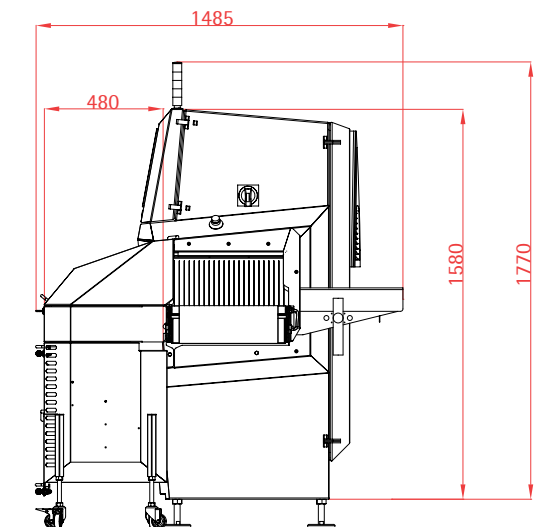

Rear view

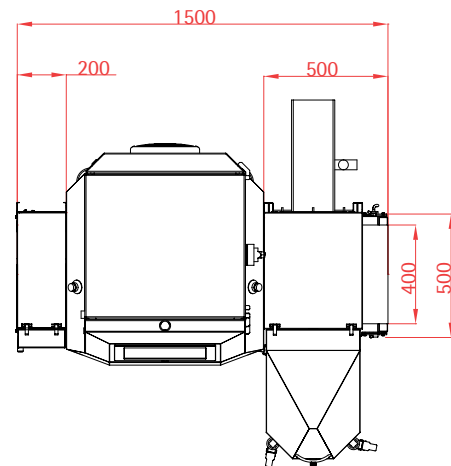

Dymond 120

Front view

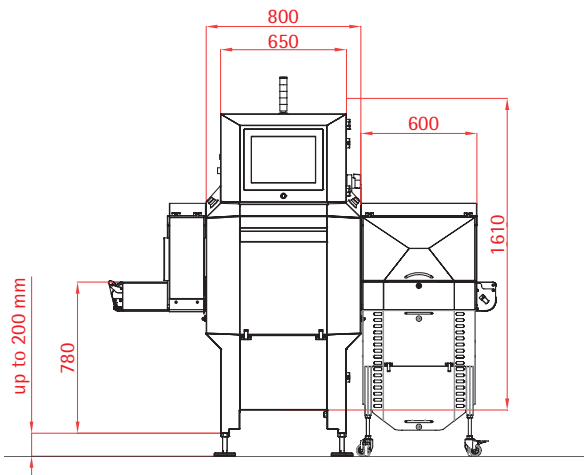

X-ray beam geometry

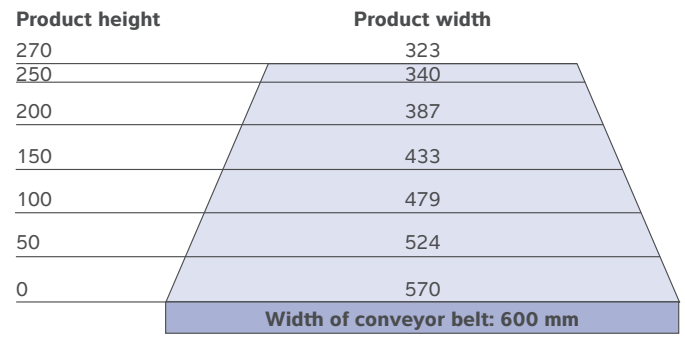

Side view

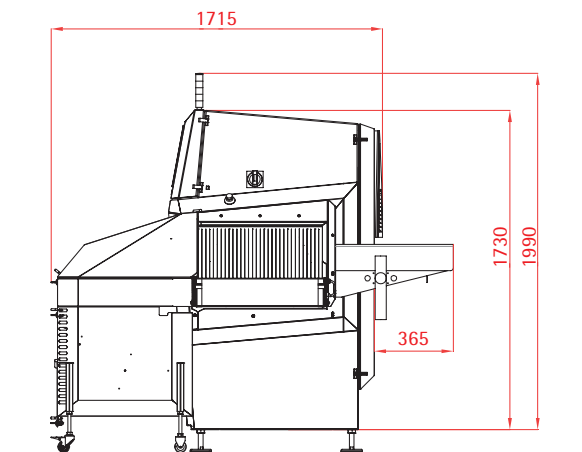

Rear view

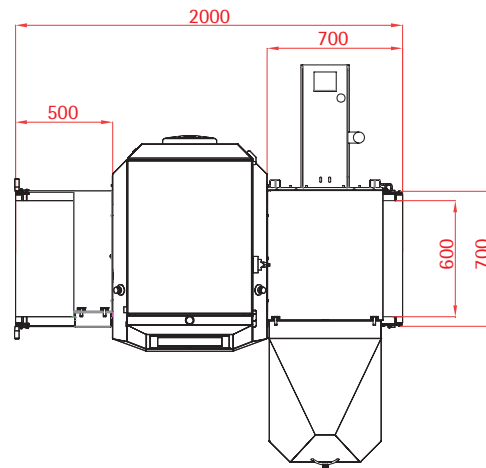

Dymond 160

Front view

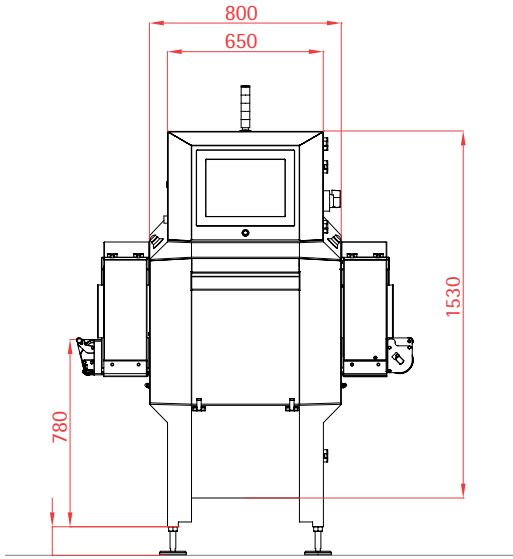

X-ray beam geometry

Product height

Product width

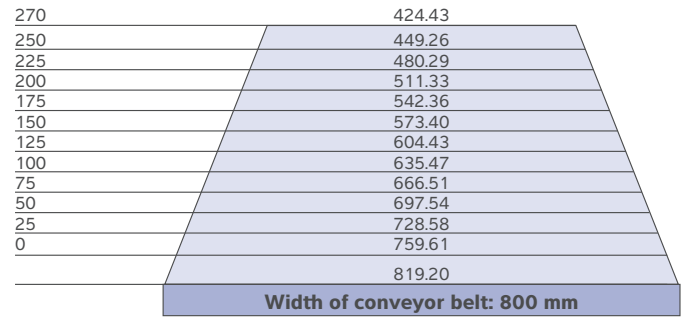

Side view

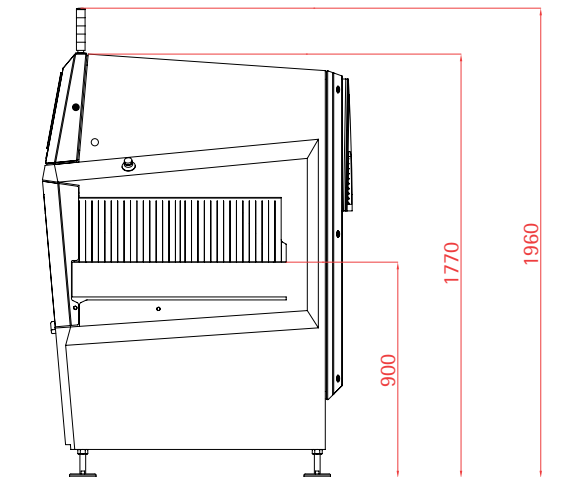

Rear view

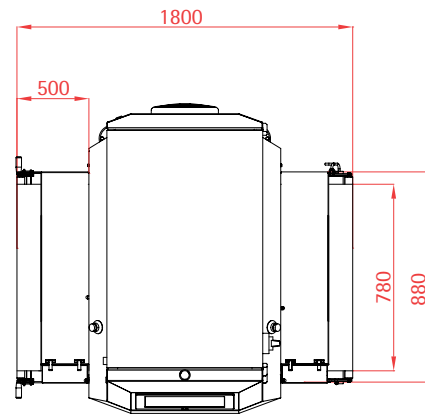

Technical specifications

Technical data – X-ray inspection system Dymond				
	Dymond 40	Dymond 80	Dymond 120	Dymond 160
X-ray power	70 kV, 1.2 mA	70 kV-1.2 mA 80 kV-2 mA	80 kV, 2 mA	90 kV, 3.5 mA
Detector resolution	0.4 mm (standard)	0.8 or 0.4 mm	0.8 mm (standard)	0.8 mm (standard)
Belt speed range	10 to 49 m/min (with standard drum motor)/ up to 73 m/min	10 to 49 m/min (with standard drum motor)/ up to 73 m/min	10 to 49 m/min (with standard drum motor)/ up to 79 m/min	10 to 49 m/min (with standard drum motor)/ up to 79 m/min
Approvals	CE, UL/CSA	CE, UL/CSA	CE, UL/CSA	CE, UL/CSA
Safety locks	SIL 3 Category IV PL e, magnetic	SIL 3 Category IV PL e, magnetic	SIL 3 Category IV PL e, magnetic	SIL 3 Category IV PL e, magnetic
User interface	15-inch touchscreen	15-inch touchscreen	15-inch touchscreen	15-inch touchscreen
Operating temperature	+5°C to +40°C with air cooling / +5°C to +30°C without air cooling	+5°C to +40°C	+5°C to +40°C	+5°C to +40°C
Machine cooling	500 W air cooling (optional with Nema4X / IP65)	500 W air cooling (optional with Nema4X / IP65)	500 W air cooling (optional with Nema4X / IP65)	500 W air cooling (optional with Nema4X / IP65)
Relative air humidity	20% to 90%, no condensation	20% to 90%, no condensation	20% to 90%, no condensation	20% to 90%, no condensation
Digital outputs	4 available	4 available	4 available	4 available
Digital inputs	7 available	7 available	7 available	7 available
USB port	Yes	Yes	Yes	Yes
Network connection	Ethernet	Ethernet	Ethernet	Ethernet
Compressed air	5.5 to 6.9 bar	5.5 to 6.9 bar	5.5 to 6.9 bar	5.5 to 6.9 bar
Radiation protection	FDA CFR 21 part 1020.40 (additional regional certifications available from the manufacturing plant)	FDA CFR 21 part 1020.40 (additional regional certifications available from the manufacturing plant)	FDA CFR 21 part 1020.40 (additional regional certifications available from the manufacturing plant)	FDA CFR 21 part 1020.40 (additional regional certifications available from the manufacturing plant)
International protection class	IP 34 (standard) / IP 65 with Nema4X air cooling / IP69K on request	IP 34 (standard) / IP 65 with Nema4X air cooling / IP69K on request	IP 34 (standard) / IP 65 with Nema4X air cooling / IP69K on request	IP 34 (standard) / IP 65 with Nema4X air cooling / IP69K on request
Electrical supply	230 V AC ± 10% (standard) / 190 to 240 V AC 50/60 Hz	230 V AC ± 10% (standard)	230 V AC ± 10% (standard) / 190 to 240 V AC 50/60 Hz	230 V AC ± 10% (standard) / 190 to 240 V AC 50/60 Hz
Max. product size	See X-ray beam geometry. Possibly lower through protective curtains.	See X-ray beam geometry. Possibly lower through protective curtains.	See X-ray beam geometry. Possibly lower through protective curtains.	See X-ray beam geometry. Possibly lower through protective curtains.
Max. throughput*, depending on product length	80 m/minute	40 m/minute or 80 m/minute* depending on detector	40 m/minute	40 m/minute
Max. power consumption	16 A	16 A	16 A	16 A
Weight (standard configuration)	450 kg	500 kg	600 kg	680 kg
Height	800–999 mm	800–999 mm	800–999 mm	800–999 mm

Connectivity

- Ethernet
- ModBus
- OPC-UA
- SPC@Enterprise

Options

Various additional options

- Remote control
- Barcode reader
- Acoustic signal emitter
- Service contracts
- Extended warranties
- Separation and
fill level monitoring
- Air pressure monitoring
- Lateral guides
- Safety guards

Ejection systems

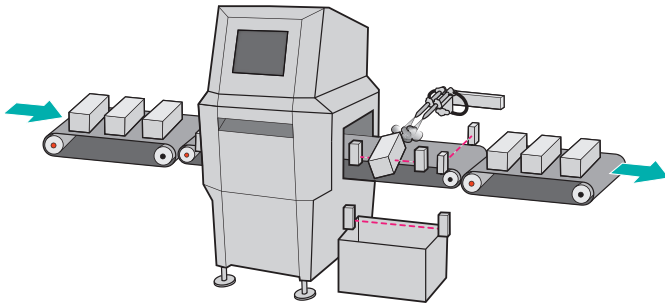

X-ray inspection system with pulse blow out ejector

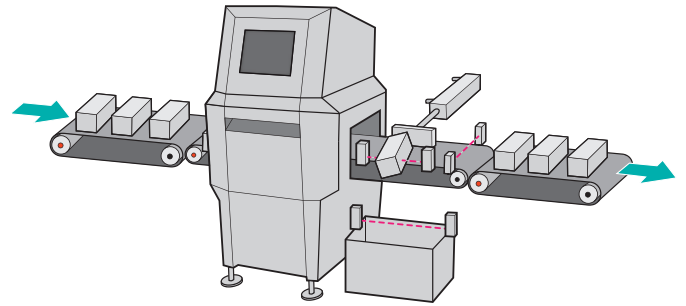

X-ray inspection system with pusher

Standard collection container

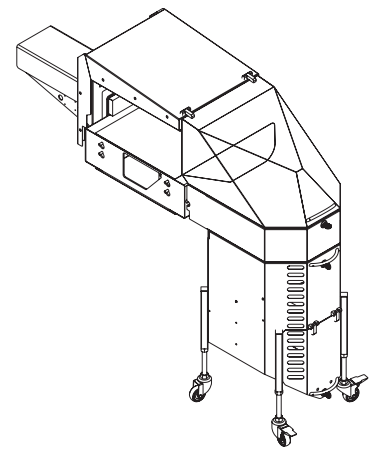
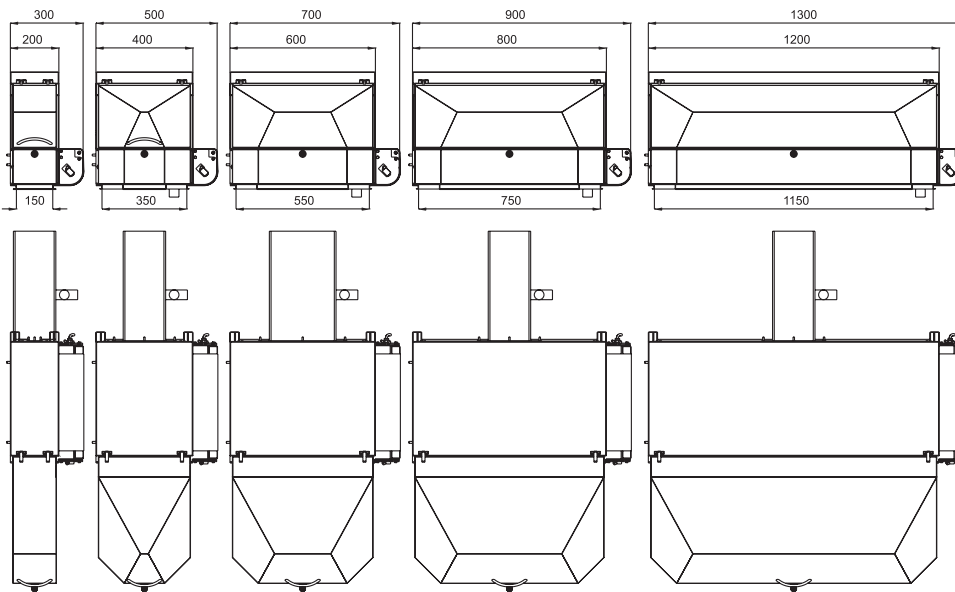

Example:
Collection container
Dymond 80

Depending on model and product length, various lockable collection containers are available. Digital lock also available.

The technical data given serves as a product description only and should not be understood as guaranteed properties in the legal sense.

Specifications subject to change without notice.

Last updated 03/2019

UK Inspection Systems Ltd
Unit 15, Hercules Way
Farnborough Aerospace Centre
Farnborough, Hampshire GU14 6UU
Tel: 01252 510565
sales@ukinspectionssystems.com
www.ukinspectionssystems.com