



AEGIS PLUS COMBINATION UNIT

Designed for Food & Packaging Industries

The Aegis Plus combination unit has been designed with the customer in mind by delivering low cost of ownership and simple maintenance. The Aegis Plus is supplied in full retail compliance configuration and has, we believe, eliminated the persistent problems encountered during operation and servicing, over many years in the industry.



Features include:

- Designed and built in the UK
- Washdown IP66 rated
- Multilevel password protection
- Enhanced USB security key option
- Full range of aperture sizes to suit products inspected
- Delivers high detection performance to withstand the demanding rigours of the industry
- Supermarket Compliance Specifications
- 10" colour monitor and touchscreen user interface
- Power save option
- Constructed to minimise bug traps but facilitate easy and effective washdown

The system combines a high-performing and reliable search head with an extremely robust weigh table, conveyor and control system.

The search head can be supplied in a variety of sizes to suit most standard applications and uses powerful Digital Signal Processing technology and high sensitivity levels to ensure the detection of the smallest ferrous, non-ferrous, and stainless-steel contaminants.

Weigh table length can be varied 'in-situ' between 350mm and 500mm without affecting the overall length of the conveyor. This flexibility allows the machine to accommodate different sizes of products reducing the need for additional capital expenditure for new product launches.

The machine handing can be changed relatively simply. This feature allows the machine to adapt with future changes to factory configuration and reduces the need for new machinery purchases.

The running gear is accessed quickly through drop down guarding, which permits quick yet extensive access for clean down and maintenance activity and the tables have been designed to allow quick changes of transport belts, drive motors and rollers.

The machine has a power save option that saves energy and reduces wear on running gear components.



AEGIS PLUS COMBINATION UNIT

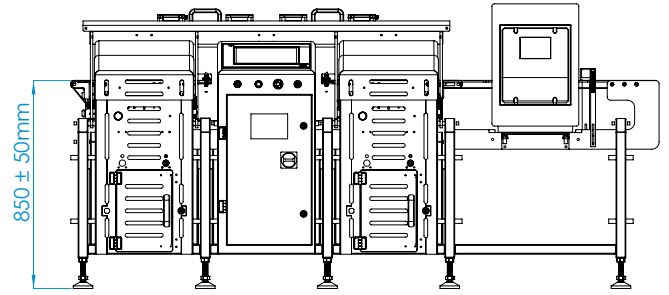
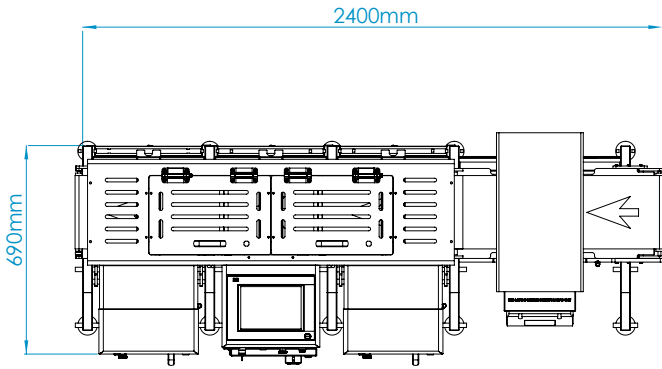

Specification

Weight capacity:	2000g
Weight range:	50g to 2000g
Belt speed:	20 to 60m/min
Min conveyor size:	200mm (W) x 350mm (L)
Max conveyor size:	300mm (W) x 500mm (L)
Head size:	Various sizes available
Height:	850mm +/- 50mm
Length:	2400mm
Width:	690mm
Belt type:	PU
Belt width:	300mm
Failsafe	Full retail compliance config
Reject:	Air blast or overhead pusher
Electrical:	220-240V single phase 16 Amp 50-60Hz
Warranty:	1 year

Applications

- Bakery
- Cereal
- Confectionery
- Dairy
- Fish
- Packaged Products
- Fruit & Vegetables
- Meat & Poultry
- Nuts & Grains
- Snack Foods
- Dried Fruits

Options

- Ethernet
- Data Collection
- Spares Kit
- Extended Warranty
- Production Support Package



☎ 01252 510565

✉ sales@ukinspectionssystem.com

🌐 www.ukinspectionssystem.com

Head Office:

Unit 15, Hercules Way
Farnborough Aerospace Centre
Farnborough
Hampshire, GU14 6UU

Manufacturing:

Units 5 & 6, Elan Court
Norris Way
Rushden
Northants, NN10 6BP



Registered in England: Number 06932748